

# TEKNOTES TASARIM

*Slaughterhouse Systems*

2024

SLAUGHTER SOLUTIONS

# Meat Technologies

*Et Teknolojileri*

## GET IN TOUCH

---



+90 555 893 98 01  
+90 546 844 09 04



[bilgi@mezbaha.com](mailto:bilgi@mezbaha.com)  
[www.mezbaha.com](http://www.mezbaha.com)



Sekerpinar Street, Defne Cayirova  
Region Kocaeli/Istanbul-TURKEY  
[www.teknotesgroup.com](http://www.teknotesgroup.com)  
[www.slaughterhouseturkiye.com](http://www.slaughterhouseturkiye.com)



**TEKNOTES TASARIM**  
Mezbaha Sistemleri

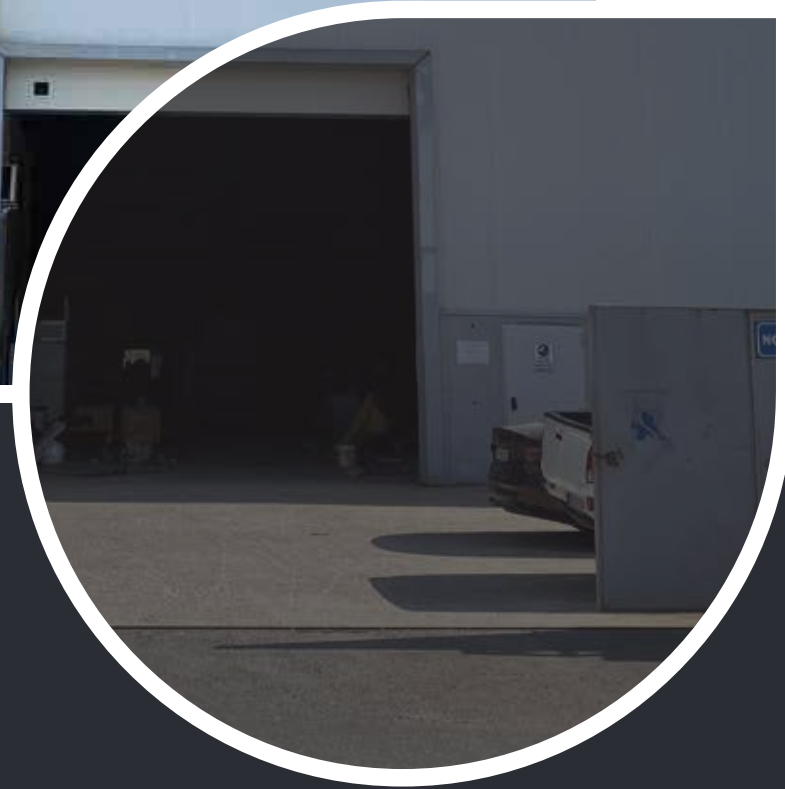

## TEKNOTES TASARIM

SLAUGHTERING TECHNOLOGY

Continues to manufacture in today's conditions as of year 2010 ,by developing itself in the design, manufacture and installation of slaughterhouse machineries and equipment. With wide range of product, releases to the market the bovine, ovine and offal equipment. We take firm steps forward towards becoming the leading company in the sector with meat integrated facility, slaughterhouse, and special sacrificial slaughterhouse facilities special to stockbreeder throughout the Turkey .

### Turnkey projects by our experienced team

Paddock systems

Steel construction

Slaughterhouse machinery and equipment

Meat processing systems

Cooling, shocking and freezing systems

2010 yılı itibari ile mezbaha makine ve ekipmanlarının tasarımı, imalatı ve montajı konusunda kendini geliştirerek günümüz koşullarında üretime devam etmektedir. Geniş ürün yelpazesi ile büyükbaş, küçükbaş ve sakatat ürünlerini piyasaya sunmaktadır. Türkiye genelinde et entegre tesisi, mezbaha ve besiciye özel özel kurbanlık tesisleri ile sektörün lider firması olma yolunda emin adımlarla ilerliyoruz.

### Deneyimli ekibimiz tarafından anahtar teslim projeler

Padok sistemleri

Çelik konstrüksiyon

Mezbaha makineleri ve ekipmanları

Et işleme sistemleri

Soğutma, şoklama ve dondurma sistemleri

# CATTLE BÜYÜKBAŞ



**TEKNOTES CUSTOM DESIGNS, MANUFACTURES  
INSTALLS CATTLE SLAUGHTERING SYSTEMS**



# MANUFACTURING İMALATÇI



**TEKNOTES** , manufactures all the cattle equipment needed for a slaughterhouse from paddock to slaughtering box, to slaughtering lines equipment and processing units, by conveying the experience in manufacturing systems to your project.

**TEKNOTES** , imalat sistemlerindeki tecrübesini projenize aktararak, padoktan kesim hücrelerine, kesim hattı ekipmanları ve işleme ünitelerine kadar bir kesimhanenin ihtiyacı olan tüm büyükbaş hayvan ekipmanlarını üretmektedir.



*TEKNOTES manufactures all the products to be used in slaughterhouse projects  
Mezbaha projelerinde kullanılacak tüm ürünleri TEKNOTES üretmektedir*



## TEKNOTES CUSTOM DESIGNS, MANUFACTURES AND INSTALLS CATTLE SLAUGHTERING SYSTEMS

### DAİRESEL KESİM HÜCRESİ

KLASİK KESİM HÜCRESİ  
SIĞIR KANAMA KANÇASI  
SIĞIR KANAMA VİNCİ  
SIĞIR KANAMA HATTI  
SIĞIR AKTARMA VİNCİ  
HAREKETLİ KASAP PLATFORMLARI  
GERİ DÖNÜŞ VE KANCA İNDİRME APARATI  
SIĞIR İŞLEME KONVEYÖRÜ  
HİDROLİK DERİ YÜZME MAKİNASI  
HİDROLİK İÇORGAN ÇIKARTMA PLATFORMU  
SIĞIR İŞLEME KANÇASI  
BÜYÜKBAŞ DUŞLAMA KABİNİ  
ET İNDİRME ÇEYREKLEME ELEVATÖRÜ  
ÇEYREKLEME MAKASI  
KARKAS YÜKLEME KOLU  
SIĞIR KANAMA TAVASI  
DÖŞ AÇMA TESTERESİ  
KARKAS BÖLME TESTERESİ  
DERİ BANT KONVEYÖRÜ  
KELLE AYAK BANT KONVEYÖRÜ  
SAKATAT KONVEYÖRÜ  
BACAK AÇMA VE KİTLEME EKİPMANI  
TİLLE  
AYAK & BOYNUZ KESME MAKASI  
KELLE YIKAMA KABİNİ

### ROTATIONARY RITUAL TRAP (KILLING BOX)

CLASSIC CUTTING CABIN  
CATTLE BLEEDING HOOK  
CATTLE BLEEDING HOIST  
CATTLE BLEEDING LINE  
CATTLE TRANSFER ELEVATOR  
MOBILE BUTCHER PLATFORMS  
RETURN AND HOOK LOWERING APPARATUS  
CATTLE PROCESSING CONVEYOR  
SKIN DEHIDER MACHINE  
VISCERA REMOVAL PLATFORM  
CATTLE PROCESSING HOOK  
CATTLE SHOWER CABIN  
MEAT LOWERING AND QUARTERING ELEVATOR  
QUARTERS SAW  
CARCASS LOADING ARM  
CATTLE BLEEDING PAN  
BRISKET OPENING SAW  
CARCASS SPLITTING SAW  
SKIN BELT CONVEYOR  
HEAD FOOT BELT CONVEYOR  
OFFAL CONVEYOR  
LEG OPENING AND LOCKING EQUIPMENT  
TILL  
HORN & FOOT CUTTING SAW  
HEAD WASH CABINET

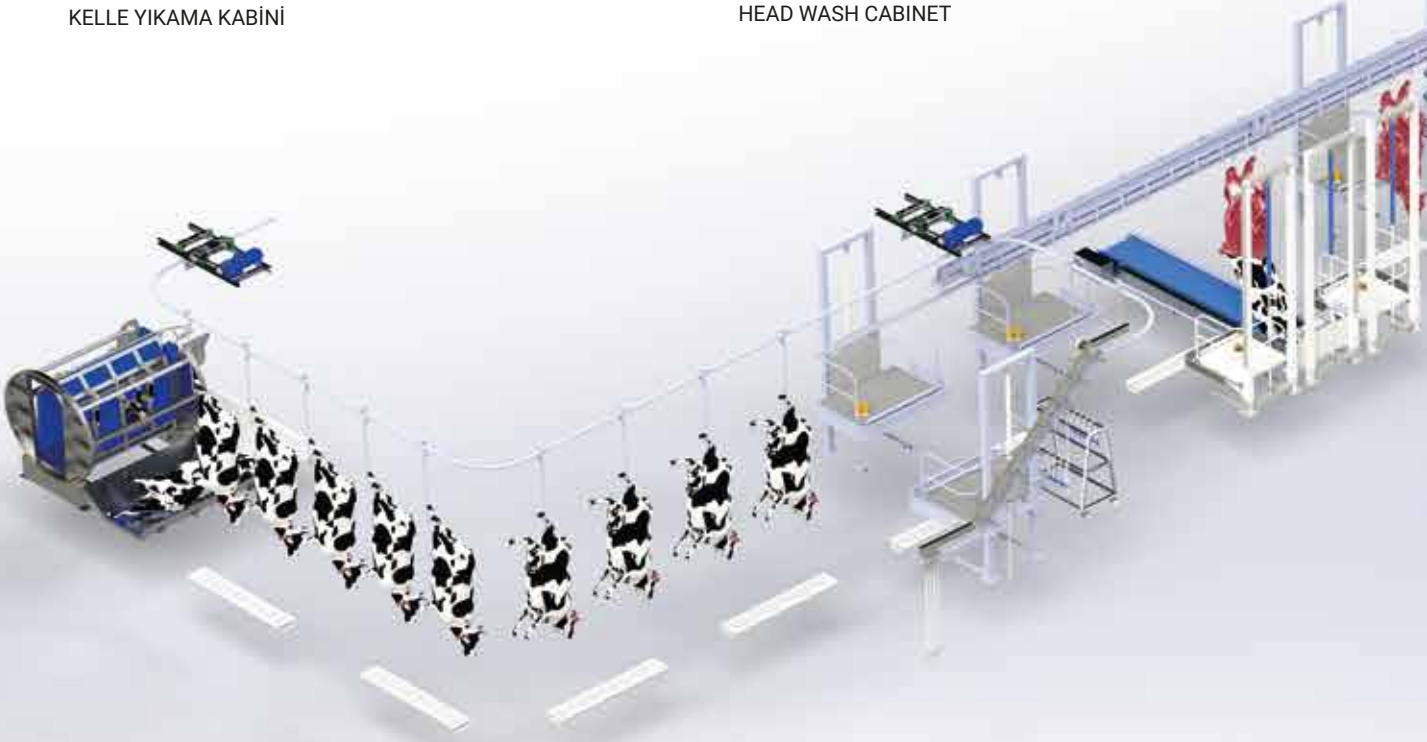

# BÜYÜKBAŞ MEZBAHANE SİSTEM ve EKİPMANLARI

## CATTLE SLAUGHTERHOUSE SYSTEMS and EQUIPMENTS

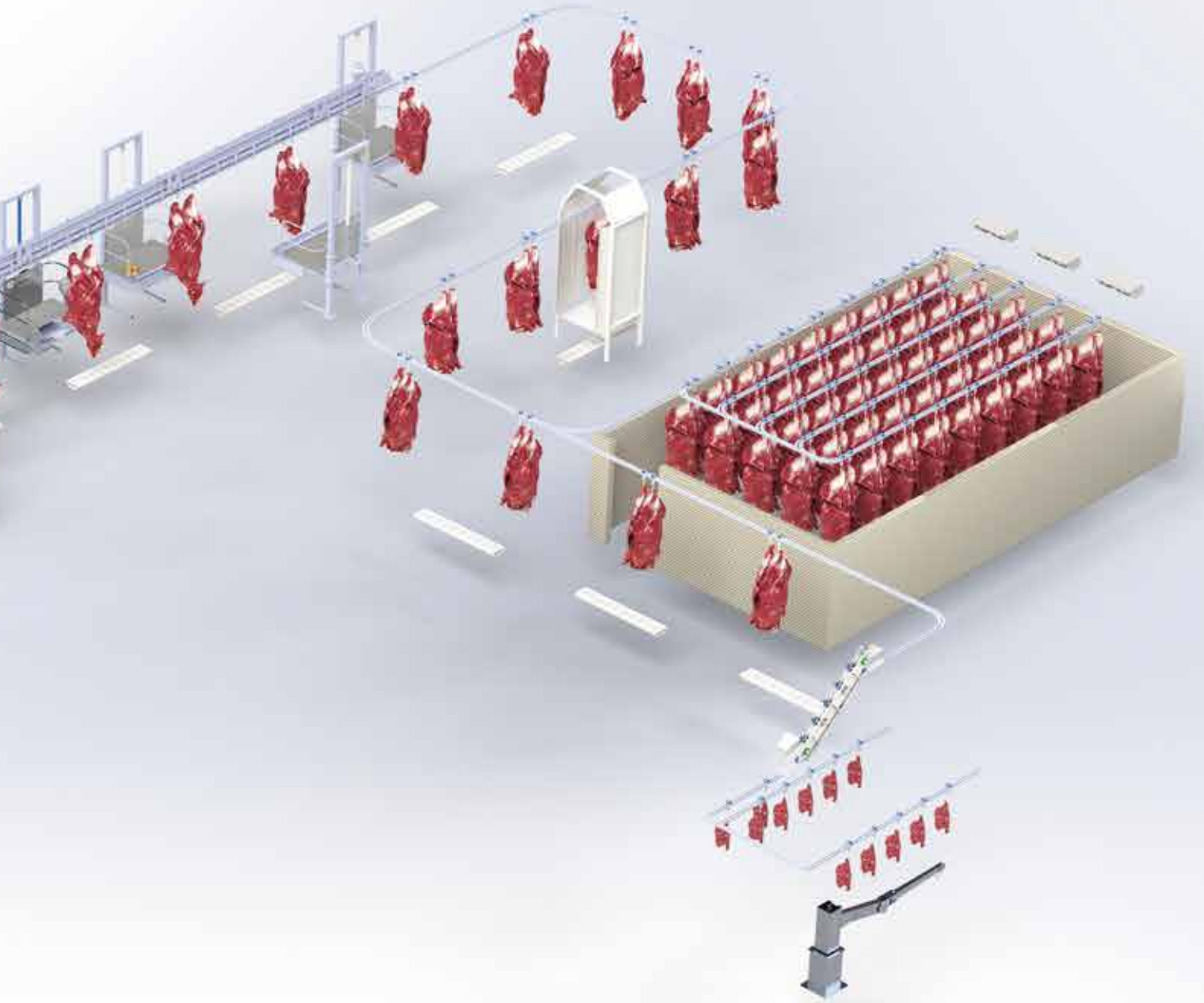

## ROTATIONARY RITUAL TRAP (KILLING BOX) DAİRESEL KESİM HÜCRESİ

Engine Power: 4 kW / 5.2 hp  
Weight: 3000 kg  
Length: 2000mm  
Width: 2600 mm  
Length: 2500 mm  
Pressure: 6-8 Bar

Motor Gücü: 4 kW / 5.2 hp  
Ağırlık: 3000 kg  
Uzunluk: 2000 mm  
En: 2600 mm  
Boy: 2500 mm  
Basınç: 6-8 Bar



It is fully automatic and appropriate for halal slaughtering.  
The animal is taken in the equipment from the back door.

Tam otomatiktir. Helal kesime ve işçi sağlığı-güvenliği kriterlerine uygundur.

## CATTLE STUNNING BOX KLASİK KESİM HÜCRESİ

Height: 2800mm  
Width: 1000 mm  
Length: 2500 mm  
Pressure: 6 Bar

Yükseklik: 2800 mm  
En: 1000 mm  
Boy: 2500 mm  
Basınç: 6 Bar





**BLEEDING HOIST  
KANAMA VİNCİ**

7.5 kW brake Reducer Motor  
Material: Galvanized  
2.000 Kg Carrying Capacity

7,5 kW Fren Redüktörlü Motor  
Malzeme: Galvanizli  
2.000 Kg Taşıma Kapasitesi

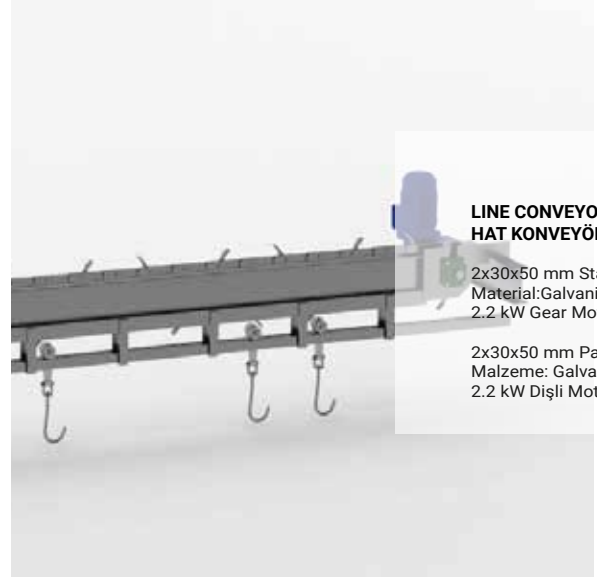

**LINE CONVEYOR  
HAT KONVEYÖRÜ**

2x30x50 mm Stainless  
Material:Galvanized Body  
2.2 kW Gear Motor

2x30x50 mm Paslanmaz  
Malzeme: Galvanizli Gövde  
2.2 kW Dişli Motor



**TRANSFER UNIT  
AKTARMA ÜNİTESİ**

Hydraulic-Pneumatic System  
1,500-2,000 Kg Carrying Capacity  
Stainless

Hidrolik-Pnömatik Sistem  
1.500-2.000 Kg Taşıma Kapasitesi  
Paslanmaz

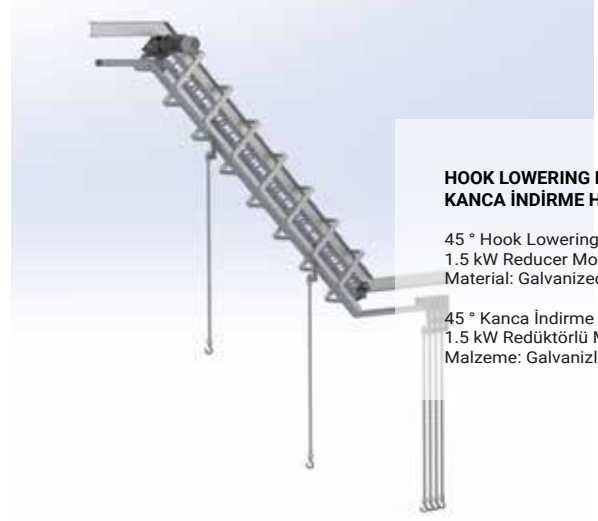

**HOOK LOWERING HELIX  
KANCA İNDİRME HELEZONU**

45 ° Hook Lowering Apparatus  
1.5 kW Reducer Motor  
Material: Galvanized

45 ° Kanca İndirme Aparatı  
1.5 kW Redüktörlü Motor  
Malzeme: Galvanizli



**SKIN DEHIDER MACHINE  
DERİ YÜZME MAKİNESİ**

Capacity: 40 Skinning Per Hour  
System: Hydraulic  
Stainless & Galvanized

Kapasite: Saatte 40  
Sistem: Hidrolik  
Paslanmaz ve Galvanizli



**EXTRACTION PLATFORM  
İÇ ORGAN ÇIKARMA PLAT.**

Moving Platform  
System: Hydraulic-Pneumatic  
Material: Stainless

Hareketli platform  
Sistem: Hidrolik-Pnömatik  
Malzeme: Paslanmaz



#### **CARCASS LOADING ARM KARKAS YÜKLEME KOLU**

Material: Stainless-Galvanized  
System: Hydraulic-Pneumatic  
270° Mobility

Malzeme: Paslanmaz-Galvanizli  
Sistem: Hidrolik-Pnömatik  
270° Hareketlilik



#### **MEAT LOWERING QUARTERING ELEVATOR ET İNDİRME VE ÇEYREKLEME ELEVATÖRÜ**

Lowering ¼ Carcasses of 45 °  
1.5 kW Gear Motor  
Material: Galvanized

¼ Karkasların 45 ° düşürülmesi  
1.5 kW Dişli Motor  
Malzeme: Galvanizli



#### **BAND CONVEYOR BANT KONVEYÖRÜ**

Material: Stainless  
1.1 kW Gear Motor  
System : Modular Tape

Malzeme: Paslanmaz  
1.1 kW Dişli Motor  
Sistem : Modüler Bant



#### **BUTCHER PLATFORM KASAP PLATFORMU**

Material: Stainless-Galvanized  
System: Hydraulic-Pneumatic  
Capacity: Min.200 Kg

Malzeme: Paslanmaz-Galvanizli  
Sistem: Hidrolik-Pnömatik  
Kapasite: Min.200 Kg



# SHEEP KÜÇÜKBAŞ

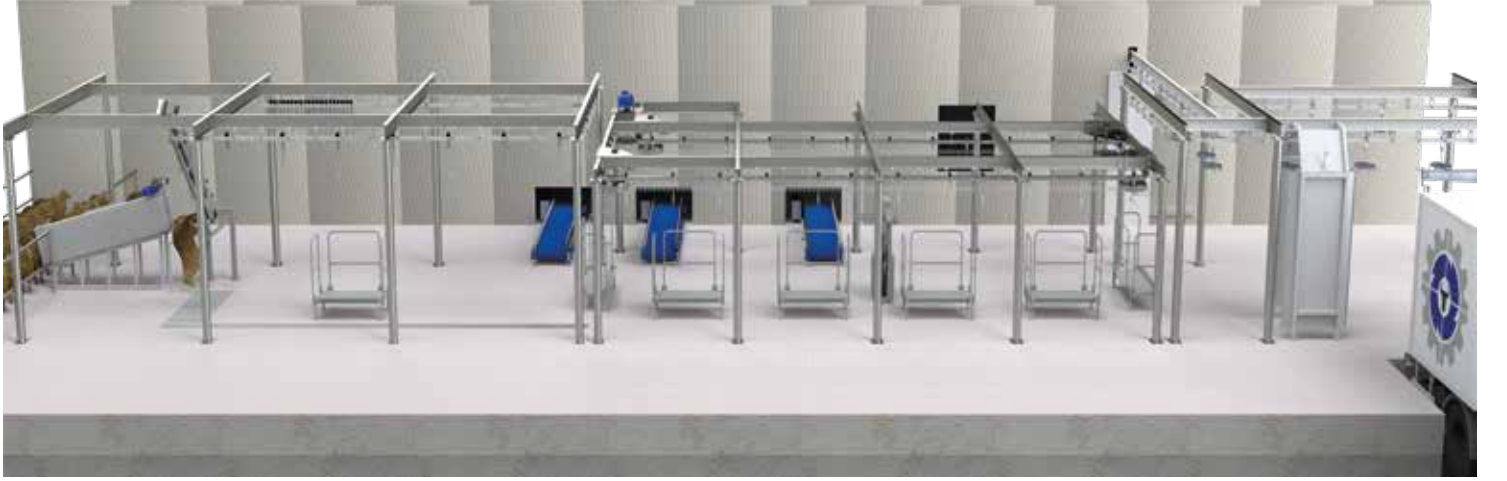

**TEKNOTES CUSTOM DESIGNS, MANUFACTURES  
INSTALLS SHEEP SLAUGHTERING SYSTEMS**



# MANUFACTURING İMALATÇI



*TEKNOTES , manufactures all the sheep equipment needed for a slaughterhouse from paddock to slaughtering box, to slaughtering lines equipment and processing units,by conveying the 11 years of experience in manufacturing systems to your project.*

*TEKNOTES, imalat sistemlerindeki 11 yıllık tecrübesini projenize aktararak, padoktan kesim hücrelerine, kesim hattı ekipmanları ve işleme ünitelerine kadar bir kesimhanenin ihtiyacı olan tüm küçükbaş hayvan ekipmanlarını üretmektedir.*



*TEKNOTES manufactures all the products to be used in slaughterhouse projects  
Mezbaha projelerinde kullanılacak tüm ürünleri TEKNOTES üretmektedir*



TEKNO  
SLAUGHTERHOUSE TECHNOLOGIST



## **SHEEP & GOAT**

TEKNO CUSTOM DESIGNS,  
MANUFACTURES AND INSTALLS  
**SHEEP SLAUGHTERING** SYSTEMS.

**KÜÇÜKBAŞ MEZBAHANE SİSTEM ve EKİPMANLARI**  
SHEEP SLAUGHTERHOUSE SYSTEMS and EQUIPMENTS





#### **SHEEP FIXING MACHINE**

It is made of stainless steel, with adjustable width, it can be used for every kind of sheep. After placing the sheep in the platform, it is elevated to the highest level with the movable conveyor. Following the slaughter by the butcher, the sheep is transferred to the bleeding pan

#### **SHEEP LIFTING ELEVATOR**

Slaughtered sheep is transferred to the bleeding conveyor by sheep lifting elevator.

#### **BLEEDING CONVEYOR**

Slaughtered sheeps bleed and move towards processing section on this automatic conveyor. The head and foot are removed in this section and prepared for transferring to the processing section.

#### **PROCESSING CONVEYOR**

Sheep's skin, internal organs and offal are removed on thi automatic conveyor. Carcasses are prepared for resting and loading. Carcasses are hung to the multiple hooked special sheep trolley at the end of the processing line and transferred to the cold rooms and loading point.

#### **BUTCHER WORKING PLATFORM**

These fixed working platforms are designed for butchers to provide comfortable and efficient working environment. All platforms have basins and knife sterilization units on it.

#### **SHEEP DEHIDER**

The sheep dehiding machine operates in a manner touching the meat and skin at the minimum level and reduces the damage. It is ideal for the sheep and goat. The sheep dehiding machine consist of parts movable from the top to the bottom. With the help of a chain fixed to the skin, the drum is wrapped downwards and the skin is separated from the carcass in a short time.

#### **MEAT LOWERING ELEVATOR**

This elevator is used for lowering carcasses from high line.





#### **KOYUN SABİTLEME ÜNİTESİ**

Paslanmaz çelikten imalatı yapılır. Ayarlanabilir genişliği sayesinde, hemen hemen her cins küçükbaş için kullanılabilir. Küçükbaş hayvan sabitleme makinasına girdikten sonra hareketli konveyör sayesinde makinanın en üst bölümüne gelir. Kasap tarafından kesim işlemi gerçekleştirilmesinin ardından koyun kanama tavasına düşürülür.

#### **KOYUN KALDIRMA ELEVATÖRÜ**

Küçükbaş hayvanın kesim işleminden sonra kanama konveyörüne alınması sağlayan otomatik sistemdir.

#### **KANAMA KONVEYÖRÜ**

Küçükbaş hayvanın kesim işlemi gerçekleştirildikten sonra kanama işleminin yapıldığı otomatik konveyör-dür. Bu bölümde kelle alınır ve ayaklar açılıp kesilerek işleme hattı transferine uygun hale getirilir.

#### **İŞLEME KONVEYÖRÜ**

Küçükbaş karkası deri, iç organ ve sakadatından ayırma işleminin yapıldığı otomatik hattır. Bu bölümde küçükbaş karkas dinlendirmeye ve sevkiyata hazır hale getirilir. İşleme konveyörünün bitiminde kapasiteye göre karkaslar çoklu kancalı arabalara aktarılır.

#### **KASAP ÇALIŞMA PLATFORMU**

Kasapların hat üzerinde rahat ve verimli çalışmalarına olanak verecek biçimde tasarlanmış sabit platformlardır. İç organ alma, sakatat çıkarma ve hatlar arası transfer işlemlerini gerçekleştirmek için kullanılır. Platform üzerinde lavabo ve bıçak sterilize üniteleri mevcuttur.

#### **KOYUN DERİ YÜZME İSTASYONU**

Deri yüzme makinası, hareketli tamburu sayesinde ete zarar vermeden koyun derisinin yüzülmesini sağlar. Hareketli tambur, deriye takılan zincir ile kısa sürede derinin yukarıdan aşağıya yüzülmesini sağlar.

#### **ET İNDİRME ELEVATÖRÜ**

Karkas etin yüksek hattan indirilmesini sağlayan otomatik sistemdir.





**SHEEP ELEVATOR  
KOYUN KALDIRMA ELEVATÖRÜ**

Transfer to the Monorail line of 45 °  
1.5 kW Gear Motor  
Material: Galvanized

45 ° Monoray hattına transfer  
1.5 kW Dişli Motor  
Malzeme: Galvanizli



**BLEEDING LINE  
KANAMA HATTI**

2x30x50 mm Stainless  
Material:Galvanized Body  
NPI-NPU profile chassis and carriers

2x30x50 mm Paslanmaz  
Malzeme: Galvanizli Gövde  
NPI-NPU profil ve taşıyıcılar



**BUTCHER PLATFORMS  
KAŞAP PLATFORMLARI**

Platform chassis 40X40 mm  
Size 1200 \*2000 \*600 mm  
Material: Stainless-Galvanized

Platform şasi 40X40 mm  
Boyut 1200 \* 2000 \* 600 mm  
Malzeme: Paslanmaz-Galvanizli

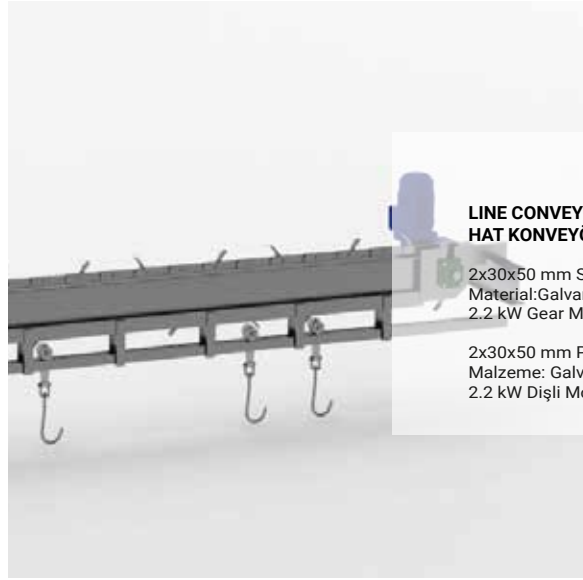

**LINE CONVEYOR  
HAT KONVEYÖRÜ**

2x30x50 mm Stainless  
Material:Galvanized Body  
2.2 kW Gear Motor

2x30x50 mm Paslanmaz  
Malzeme: Galvanizli Gövde  
2.2 kW Dişli Motor

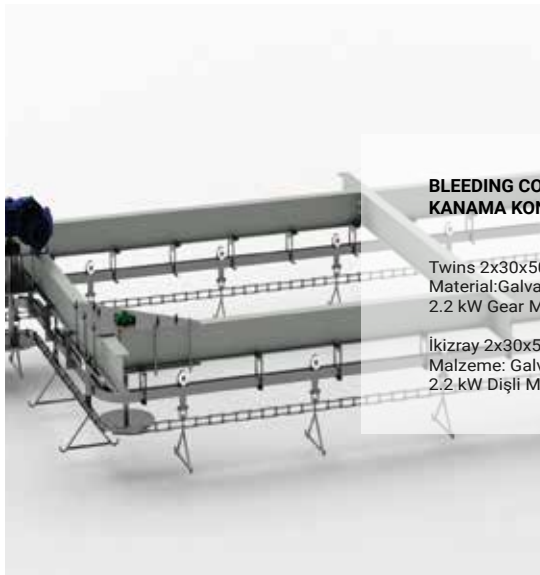

**BLEEDING CONVEYOR  
KANAMA KONVEYÖRÜ**

Twins 2x30x50 mm Stainless  
Material:Galvanized Body  
2.2 kW Gear Motor

İkizray 2x30x50 mm Paslanmaz  
Malzeme: Galvanizli Gövde  
2.2 kW Dişli Motor



**SHEEP HANGER  
KOYUN ASMA ARABASI**

Capacity : 600-800 Kg  
Twins Hook Up 6s - 8s  
Stainless Steel

Kapasite : 600-800 Kg  
İkizler 6'lı - 8'li Kanca  
Paslanmaz çelik



### SKIN DEHIDER MACHINE DERİ YÜZME MAKİNESİ

Capacity: 40 Skinning Per Hour  
System: Hydraulic  
Stainless & Galvanized

Kapasite: Saatte 40 Deri Soyma  
Sistem: Hidrolik  
Paslanmaz ve Galvanizli



### SHEEP FIXING UNIT KOYUN SABİTLEME MAKİNESİ

Between Drum Axes: 3040 mm  
1.1 kW geared motor  
Band Quantity: 2 Pieces

Tambur Eksenleri Arası: 3040 mm  
1.1 kW dişli motor  
Bant Miktarı: 2 Adet



### SHOWER CABIN DUŞLAMA KABİNİ

Sprinkler system with stainless  
nozzle  
Stainless steel  
Ø 1/2 pipe shower system

Paslanmaz nozullu  
Paslanmaz çelik  
Ø 1/2 borulu duş sistemi



### BLEEDING PAN KANAMA TAVASI

AISI 304 Stainless (20\*25\*2 mm)  
Material:Stainless  
Two outputs

AISI 304 Paslanmaz (20\*25\*2 mm)  
Malzeme: Paslanmaz  
iki çıkış



### BAND CONVEYOR BANT KONVEYÖRÜ

Material: Stainless  
1.1 kW Gear Motor  
System : Modular Tape

Malzeme: Paslanmaz  
1.1 kW Dişli Motor  
Sistem : Modüler Bant



### BLEEDING PULLEY KANAMA MAKARASI

Material: Stainless-Galvanized

Malzeme: Paslanmaz-Galvanizli

# OFFAL CLEANING EQUIPMENTS

## Sakatat Temizleme Makineleri

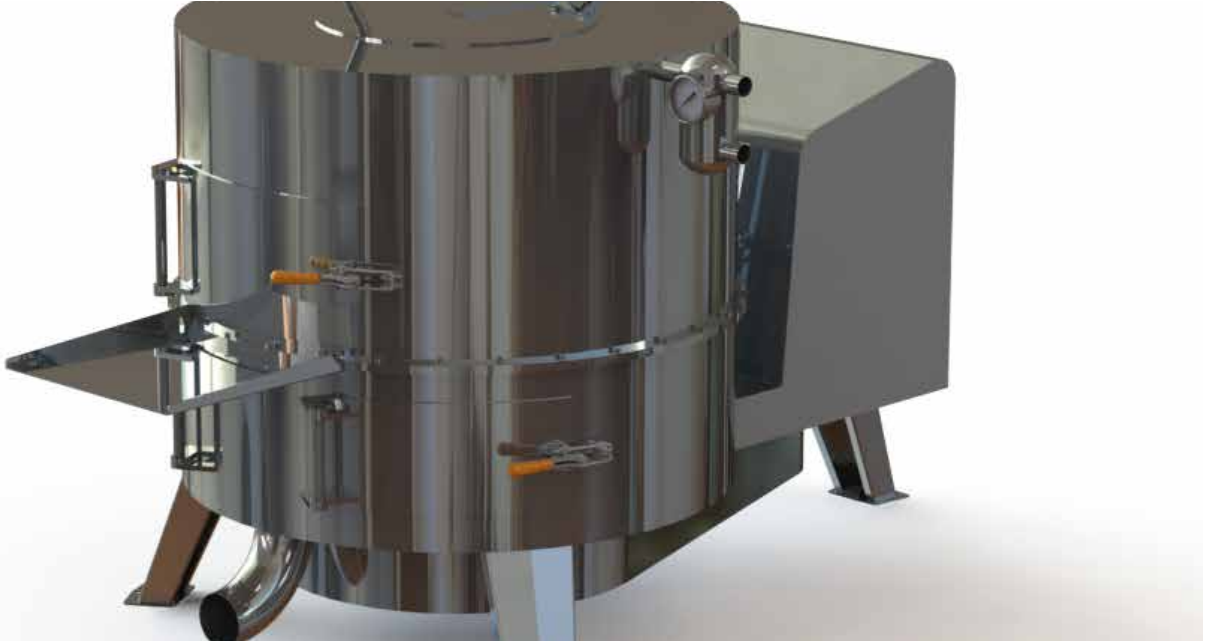

### TRIPLE CLEANING MACHINE İŞKEMBE TEMİZLEME MAKİNESİ

7.5 Tons of tripe in 10 hours  
Cleaning time 10 minutes  
Cleaning : 100%  
Cleaning Temperature: 70 C°  
7.5-11 KW double speed motor  
Machine dimensions: 120 \* 100 \* 200 cm  
Weight:550 kg  
polyester board

10 saatte 7.5 Ton işkembe  
Temizleme süresi 10 dakika  
Temizleme : %100  
Temizleme Sıcaklığı:70 C°  
7.5-11 KW çift devirli motor  
Makine ölçüleri:120\*100\*200 cm  
Ağırlık:550 kg  
polyester pano

### CATTLE FEET CLEANING MACHINE DANA PAÇA TEMİZLEME MAKİNESİ

Cleaning time: 20 minutes  
Cleaning rate: 95%  
Cleaning Temperature: 50-60 C°  
Fully automatic polyester board  
Engine: 7.5 - 11 KW, 750 - 1500 rpm  
Height: 120 cm  
Width: 125 cm  
Length: 180 cm

Temizleme süresi:20 dakika  
Temizleme oranı:%95  
Temizleme Sıcaklığı: 50-60 C°  
Tam otomatik polyester pano  
Motor: 7.5 - 11 KW , 750- 1500 devir / dakika  
Makine ölçüleri : Yükseklik :120 cm  
Genişlik:125 cm  
Uzunluk:180 cm



## OFFAL CLEANING EQUIPMENTS



**OMASUM CLEANING MACHINE**  
KIRKBAYIR TEMİZLEME MAKİNESİ



**BOWEL CLEANING MACHINE**  
BAĞIRSAK TEMİZLEME MAKİNESİ



**HOOF REMOVAL MACHINE**  
TIRNAK SÖKME MAKİNESİ



**STORAGE BOILER**  
DEPOLAMA KAZANI

# QURBAN SLAUGHTERING CENTER PROJECT

## KURBAN KESIM MERKEZI

*Teknotes manufactures all the equipment needed for a slaughterhouse from paddock to slaughtering box, to slaughtering lines equipment and processing units*



## QURBAN SLAUGHTERING KURBAN KESIMHANESI

Features Qurban Slaughtering Center;  
Provides 300 caattles slaughtering capacity per day,  
Complies with international hygiene rules and standards,  
Provides healthy, safe and clean slaughtering environment,  
Prevents public slaughtering on the streets and keeps streets clean,  
Provides much more controllable environment for slaughtering.

Günlük 300 büyükbaş kesim kapasitesi,  
Uluslararası standartlarda hijyen kurallarına uyumluluk,  
Sağlıklı, güvenli ve temiz bir ortamda kesim olanağı,  
Şehirlerde mahalle ve sokak üzerinde kesim ihtiyacını ortadan kaldırır,  
Kesimlerin kontrol altında yapılmasını sağlar,  
Kontrolsüz kesimden kaynaklı çevre kirliliklerini ve olası hastalık tehditlerini önler.



Kurban Slaughtering Center Project is designed for easy, healthy and clean slaughtering for the public. It's designed to slaughter 300 cattle per day, but can be increased by some minor modifications depending on our customer's requests. Project design consists of parking lot, cafeteria, slaughtering hall, administration office, mosque, sales office and everything that needed.

Kurban Bayramlarında halka hizmet vermek üzere tasarlanmış Kurban Kesim Merkezi projemiz ile daha sağlıklı, güvenli, temiz ve kontrol edilebilir ortamlarda kesim olanağı sunmaktayız. Günlük 300 adet büyükbaş kesim kapasitesine sahip Kurban Kesim Merkezimiz otoparktan kafeteryaya, yönetim binasından Mescide ve satış yerine kadar vatandaşlarımızın ihtiyaç duyacağı herşey düşünülerek projelendirilmiştir.



TEKNO carries out all the construction, installation and project implementations...

# INSTALLATION AND CONTRACTING



TEKNOTES designs authentic projects providing you with the most ergonomic, efficient and affordable solutions based on your needs and capacity demand for the slaughterhouse equipment to be used in your facility.

Contracting services are provided in a fast, flawless way and tailored to your needs through excellent integrated projects in which all the necessary details are considered.

The fact that manufacturing, project designing and project implementation are solved all from a single point saves you time, bringing down the cost.

Through architectural project designing, areas such as administrative units, dining halls, showers, toilets, manufacturing yards, storehouses, entry and exit points for products are identified.

Through static project designing, ultimate load capacity of concrete- steel based on the capacity of buildings and ground- subsurface studies, bearing capacity, floor and roof plans, framework system are calculated thoroughly.

Through electrical installation projects, designed for license and implementation, projects complying with regulations are designed. Installation drawing includes the elements such as lighting, transformer, medium voltage, plug socket, fire warning, security systems, fire warning alarm, computers and data infrastructure.

Through mechanical project designing, heating, cooling, ventilating, clean and contaminated water, drainage, sanitary hot water pipes and fire extinguishing systems are thoroughly identified. Through ventilating and cooling project designing, all ventilating and cooling systems are planned based on the characteristics and capacity of the facility.

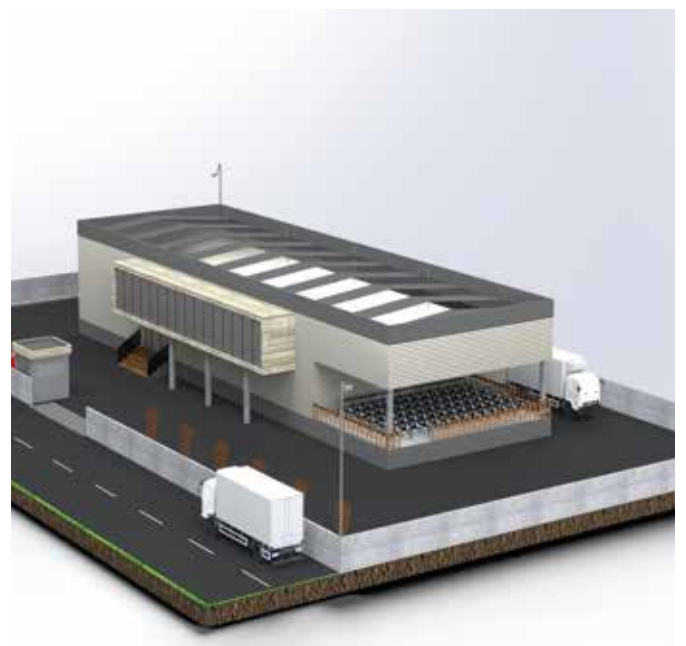

**CONSTRUCTION OF SLAUGHTER  
MEZBAHA BINA INŐAATI**



**TURNKEY PROJECT  
ANAHTAR TESLİM PROJELER**

# COOLING SYSTEMS

## COLD STORAGE



**Cold Room Panels**  
**Cold Room Evaporators**  
**Cold Room Doors**  
**Ammonia Coolers**  
**Air Cooled Condensers**  
**Dry Coolers**  
**Heat Exchangers**  
**Humidification and Ethylene Removal Devices**  
**Digital Dashboard – Remote Monitoring/Management**  
**Accessory**

Soğuk Oda Panelleri  
Soğuk Oda Evaporatörleri  
Soğuk Oda Kapıları  
Amonyaklı Soğutucular  
Hava Soğutmalı Kondenserler  
Kuru Soğutucular  
Isı Değiştiriciler  
Nemlendirme ve Etilen Alma Cihazları  
Dijital Pano – Uzaktan İzleme/Yönetme  
Aksesuar



# SOĞUTMA SİSTEMLERİ

## SOĞUK ODA



**WALL PANEL**  
DUVAR PANELİ

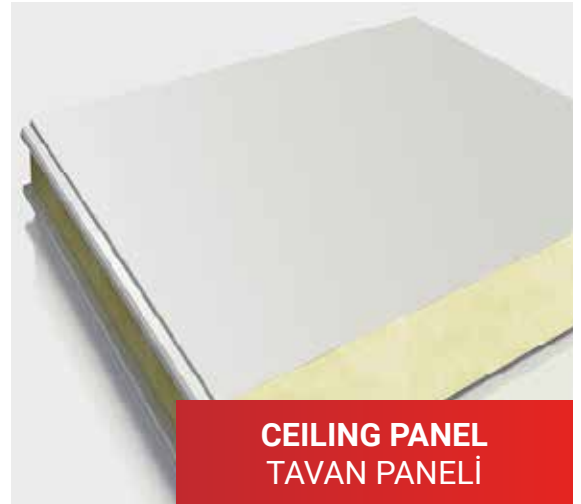

**CEILING PANEL**  
TAVAN PANELİ



**FLOOR PANEL**  
ZEMİN PANELİ

# COLDROOM DOORS

## SOĞUKODA KAPILARI

*Reliable & technological cold room doors*  
*Güvenilir & teknolojik soğuk oda kapıları*

### SLIDING COLD ROOM DOOR

CTP composite construction  
1,5 mm AMB (antimicrobial) CTP,  
painted sheet or stainless surface  
EPDM rubber based sealing system Stainless  
surface with 1,5 mm AMB  
(antimicrobial) CTP  
Anodised aluminium that prevents heat transfer  
for the door frame and blade  
Door blade : 42 kg/m<sup>3</sup> density high  
pressure polyurethane injection  
220 volt, 25 w/m silicone based  
resistance on frozen storage doors Aluminium  
profile with resistance on the floor.

### SÜRGÜLÜ SOĞUKODA KAPISI

CTP kompozit konstrüksiyon  
1,5 mm AMB (antimikrobiyel) CTP, boyalı  
sac veya paslanmaz yüzey  
EPDM kauçuk esaslı conta sistemi  
1,5 mm AMB (antimikrobiyel) CTP  
kullanımında eksiz yüzey  
engelleyen eloksallı alüminyum  
Kapı kanadı, 42 kg/m<sup>3</sup> yoğunlukta  
yüksek basınç poliüretan injeksiyon  
Donmuş muhafaza kapılarında 220 volt  
25 w/m silikon esaslı rezistans  
Zeminde rezistanslı alüminyum profil





**AUTOMATIC SLIDING COLD ROOM DOOR**  
**OTOMATİK SÜRGÜLÜ SOĞUK ODA KAPISI**



EXCELLENT LIQUIDITY  
PROPERTIES WITH RUBBER  
BASED GASKET SYSTEM

KAUÇUK ESASLI CONTA  
SİSTEMİ İLE MÜKEMMEL  
SIZDIRMAZLIK ÖZELLİĞİ



# COLDROOM DOORS

## MONORAIL SLIDING COLD ROOM DOOR MONORAY SÜRGÜLÜ SOĞUKODA KAPISI

CTP composite material  
1,5 mm AMB (antimicrobial) CTP, painted sheet or stainless surface – EPDM rubber system  
Desired color choice in door blade  
Anodised aluminium that prevents heat transfer for the door frame and blade  
Door blade : 42 kg/m<sup>3</sup> density high pressure polyurethane injection– Monorail system on door and frame  
Polyamid protecting door blade in articulated system

CTP kompozit konstrüksiyon  
1,5 mm AMB (antimikrobiyel) CTP, boyalı sac veya paslanmaz yüzey  
EPDM kauçuk esaslı conta sistemi  
1,5 mm AMB (antimikrobiyel) CTP kullanımında eksiz yüzey  
Kapı kanadında istenilen renk seçeneği  
Kapı kanadı ve kasası, ısı transferini engelleyen eloksallı alüminyum  
Kapı kanadı, 42 kg/m<sup>3</sup> yoğunlukta yüksek basınç poliüretan injeksiyon– Mafsallı ve sabit monoraylı sistem uygunluğu  
Mafsallı sistemde kapı kanadını koruyan poliamid parça  
Sabit monoraylı sisteme uygun paslanmaz yüzeyi profilleri



## HINGED COLD ROOM DOORS MENTEŞELİ SOĞUK ODA KAPILARI

Anodised aluminium that prevents heat transfer for the door frame and blade  
Door blade : 42 kg/m<sup>3</sup> density high pressure polyurethane injection  
1,5 mm AMB (antimicrobial) CTP, painted sheet or stainless surface  
Desired color choice in door blade  
Door lock that can be opened from inside (evenlocked)and outside  
Rising and adjustable hinges  
EPDM rubber system  
220 volt, 25 w/m silicone based resistors on frozen storage doors

Kapı kanadı ve kasası, ısı transferini engelleyen eloksallı alüminyum  
Kapı kanadı, 42 kg/m<sup>3</sup> yoğunlukta yüksek basınç poliüretan injeksiyon  
1,5 mm AMB (antimikrobiyel) CTP, boyalı sac veya paslanmaz yüzey  
Kapı kanadında istenilen renk seçeneği – İçerden ve dışarıdan açılabilir kapı kilidi – Yükselen tip menteşe  
EPDM kauçuk esaslı conta sistemi  
Donmuş muhafaza kapılarında 220 volt 4 25 w/m silikon esaslı rezistans

# SOĞUKODA KAPILARI



## DOUBLE WING HINGED DOOR WITH MONORAY PASSAGE ÇİFT KANAT MONORAYLI MENTEŞELİ SOĞUK ODA KAPILARI

Anodised aluminium that prevents heat transfer for the door frame and blade  
Door blade: 42 kg/m<sup>3</sup> density high pressure polyurethane injection  
1,5 mm AMB (Antimicrobial) CTP, painted sheet or stainless surface

Kapı kanadı ve kasası, ısı transferini engelleyen eloksallı alüminyum  
Kapı kanadı, 42 kg/m<sup>3</sup> yoğunlukta yüksek basınç poliüretan injeksiyon  
1,5 mm AMB (Antimikrobiyel) CTP, boyalı sac veya paslanmaz yüzey

Anodised aluminium that prevents heat transfer for the door frame and blade

Door blade: 42 kg/m<sup>3</sup> density high pressure polyurethane injection

1,5 mm AMB (antimicrobial) CTP, painted sheet or stainless surface

Desired color choice in door blade

EPDM rubber sealing system suitable for blade profile

Hinges that can be opened in and out, fixed at 90° if necessary

Impact absorbent pvc protective band

Kapı kanadı ve kasası, eloksallı alüminyum

Kapı kanadı, 42 kg/m<sup>3</sup> yoğunlukta yüksek basınç poliüretan injeksiyon

1,5 mm AMB (antimikrobiyel) CTP, boyalı sac veya paslanmaz yüzey

Kapı kanadında istenilen renk seçeneği

Yükselen tip menteşe

Kanat profiline uygun EPDM kauçuk esaslı conta sistemi

EPDM kauçuk contalı pleksiglas kapı kanadı camları

İçeri dışarı açılabilen gerektiğinde 90° de

sabitlenen menteşeli

Darbe emici PVC koruma bandı

## FLIP-FLOP DOOR FLIP-FLOP KAPI



*Reliable & technological cold room doors  
Güvenilir & teknolojik soğuk oda kapıları*



## HERMETIC SPLIT TYPE COOLING UNIT HERMETİK SPLIT TYPE SOĞUTMA ÜNİTESİ

Split Type Hermetic Capacitor Units are suitable for cold rooms and reion cooling with low capacity requirements. Small Compact design makes it easy to assemble and maintain. The Sound pressure values are at a minimum level.

Split Tipi Hermetik Kondanser Üniteleri düşük kapasite ihtiyaçlarının olduğu soğuk odalar ve reyon soğutmalarına uygundur. Küçük kompakt tasarımı sayesinde montajı ve bakımı kolaydır. Ses basınç değerleri minimum seviyededir.



## SCROLL SPLIT TYPE COOLING UNIT SCROLL SPLIT TYPE SOĞUTMA ÜNİTESİ

In Split Type Scroll Capacer Units, the sound and vibration are at a low level. in Particular, it is perfectly suited to grocery and supermarket applications. Energy consumption is minimal with energy efficiency applications.

Split Tipi Scroll Kondanser Üniteleri'nde ses ve titreşim düşük seviyededir. Özellikle market ve süpermarket uygulamalarına mükemmel uygunluktur. Enerji verimlilik uygulamasıyla enerji tüketimi minimum seviyededir.



## SEMI HERMETIC SPLIT TYPE COOLING UNIT SEMİ HERMETİK SPLIT TYPE SOĞUTMA ÜNİTESİ

SplitType Semi-Hermetic Condenser Units are suitable for low to medium capacity cooling needs. it offers wide selection options thanks to its Large capacity ranges. Long-lasting and trouble-free thanks to proven high quality compressors.

Split Tipi Semi Hermetik Kondanser Üniteleri düşük ve orta kapasitedeki soğutma ihtiyaçları için uygundur. Geniş kapasite aralıkları sayesinde geniş seçim seçeneği sunmaktadır. Kendini ispatlamış kaliteli kompresörler sayesinde uzun ömürlü sorunsuzdur.

IP55 Integrated Electrical Panel  
Easy Maintenance  
Quality Equipment  
Compatible condensers for hot environment  
Complete, Ready for Installation Compact Design  
Non-vibration operation  
Electrical Panels Compatible to the Standards  
Quick Easy Setup  
Ultra Quiet Fan Option



IPSS Entegre Elektrik Panosu  
Kolay Bakım  
Kaliteli Ekipmanlar  
Yüksek Sıcaklara Uygun Kondanser  
Komple, Kurulumu Hazır Kompakt Tasarım  
Titreşimsiz Çalışma  
Standartlara Uygun Elektrik Panosu  
Hızlı Kolay Kurulum  
Ultra Sessiz Fan Seçeneği

# BÜYÜKBAŞ AHIR ÇİFTLİĞİ

## PRODUCTS / ÜRÜNLER



**FERTILIZER SEPARATOR**  
600 MICRON  
GÜBRE SEPERATÖRÜ  
600 MICRON



**FERTILIZER PUMP 7.5 KW**  
GÜBRE POMPASI 7.5 KW



**FERTILIZER MIXER 15 KW**  
GÜBRE KARIŞTIRMA  
MAKİNASI 15 KW



**AUTOMATIC CHAIN FERTILIZER SCRAPER SYSTEM**  
OTOMATİK ZİNCİRLİ GÜBRE  
SIYIRICI SİSTEMİ



**SOLID FERTILIZER DISTRIBUTION TRAILER 15 M3**  
KATI GÜBRE DAĞITMA  
RÖMORKU 15 M3



**LIQUID FERTILIZER TRANSPORT AND DISTRIBUTION 14 TON**  
SIVI GÜBRE TAŞIMA VE  
DAĞITMA 14 TON



**DRINKER ANIMAL DRAINER WITH STAINLESS TIPPING**  
BÜYÜKBAŞ HAYVAN  
SULUĞU PASLANMAZ  
DEVİRMELİ



**AUTOMATIC ANIMAL BRUSH**  
OTOMATİK HAYVAN FIRÇASI



**ANIMAL SCALE**  
HAYVAN KANTARI

# CATTLE BREEDING FARM

Turnkey System

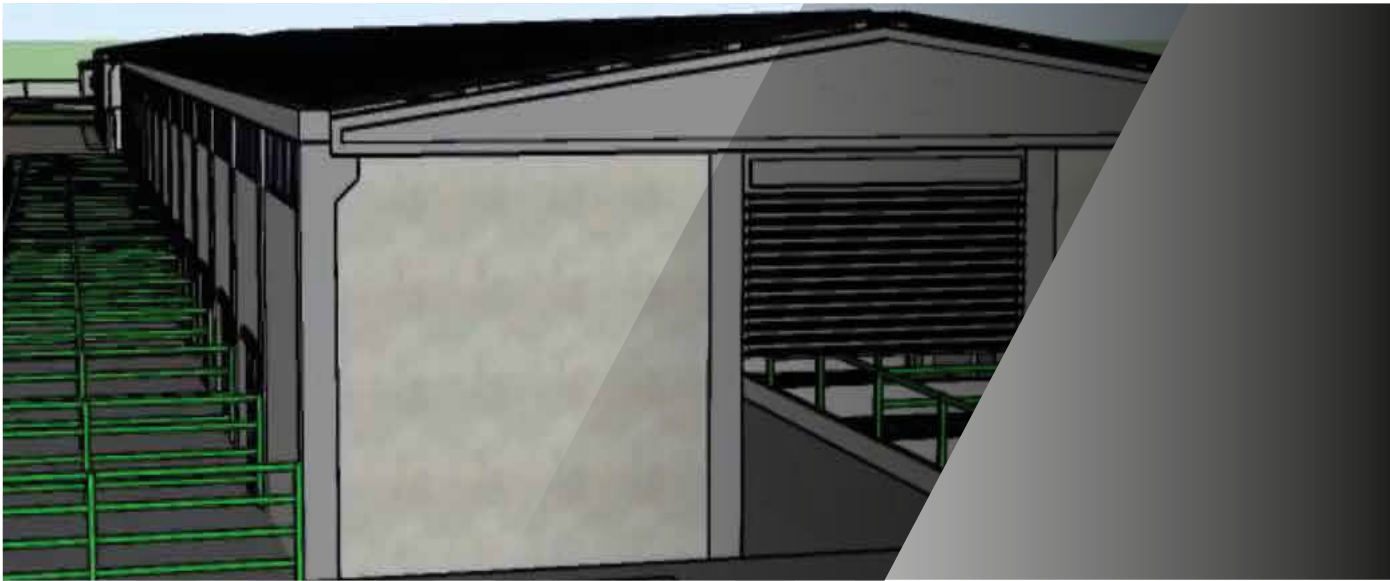

# THINK GLOBAL WORLDWIDE



## REFERENCES TEKNOTES TASARIM

OUARDIGHA VIANDES ( MOROCCO )  
TRUST TRADE LIMITED CO . ( MONGOLIA )  
Shoqata Bëmirëse Jetimat e Ballkanit (KOSOV )  
Azteserrufat Limited Liability Company ( AZERBAIJAN )  
SARL NAHOUI FOOD INDUSTRIES ( ALGERIE )  
ISM HENSON AFRICA LIMITED ( KENYA )  
Rizvan-El MMC - ye ( AZERBAIJAN )  
Qoç Et ( AZERBAIJAN )  
C.V Awal Putra Ma Rangka ( INDONESIA )  
Meat Processing And Service ( KAZAKHSTAN )  
Agrozoomed SRL ( ROMANIA )  
Kaindy LLC QUAINDY ( KAZAKHSTAN )  
Abdrassilov Farm ( KAZAKHSTAN )  
Eastern Kitchen Supplies Limited ( QATAR )  
Caritas Czech Republic in Georgia  
BEYPINAR MEZBAHASI ( TURKEY )  
Polatlı Et Kombinasi ( CAPITAL OF TURKEY ) Erzincan  
Belediyesi Et Entegre Tesisi ( TURKEY ) Antalya  
Sherwood Resorts and Hotel ( TURKEY ) Bilecik  
Belediye Mezbahasi ( TURKEY )  
Güler Et ve Et Ürünleri ( TURKEY )  
Atılğan Et ( TURKEY )  
Giresun Tirebolu Mezbahasi ( TURKEY )  
Afyon Çay Belediye Mezbahasi ( TURKEY ) Mühsüroğlu  
Et Entegre Tesisleri ( TURKEY )  
Etaş Et Ürünleri A.Ş ( TURKEY )  
Antalya Elmalı Belediye Mezbahasi ( TURKEY )  
Niğde Açık Cezaevi Et Entegre ( TURKEY )  
İSM Et Silivri ( TURKEY )  
Önder Et ( TURKEY )

Giresun Görele Belediye Mezbahasi ( TURKEY )  
Araz Et Gıda ( TURKEY )  
İmtaş Besi Çiftliği ( TURKEY )  
Bakanlar Et Kombinasi ( TURKEY )  
Nefis Et Gıda ( TURKEY )  
Konya Arvasi Mezbahasi ( TURKEY )  
Yüksel Et Gıda ( TURKEY )  
Günbeyi Et Gıda ( TURKEY )  
Kemberburgaz Sütçü Yusuf Besi Çiftliği ( TURKEY )  
Düzgün Marketçilik Gıda ( TURKEY )  
Lokmangil Besi Çiftliği ( TURKEY )  
Çetin Et ( ŞİLE , TURKEY )  
MERT KARDEŞLER BESİ ÇİFTLİĞİ ( TURKEY )  
Güven Besicilik ( TURKEY )  
Polkara Gıda ( TURKEY )  
Zafer Sucukları Et Entegre Tesisi ( TURKEY )  
Narman Açık Ceza İnfaz Kurumu ( TURKEY )  
Çorum Kargı Belediye Mezbahasi ( TURKEY )  
Kars Açık Ceza İnfaz Kurumu ( TURKEY )  
Cihan Besicilik ( TURKEY )  
ÖzKarakuş Besi Çiftliği ( TURKEY )  
Sahra Besi Çiftliği ( TURKEY )  
SPK Sucukları ( TURKEY )  
Antalya Gazipaşa Belediye Mezbahasi ( TURKEY )  
Antalya Kumluca Belediye Mezbahasi ( TURKEY )  
Sinop Belediye Mezbahasi ( TURKEY )



Ministry of Justice TURKEY

-KARS AÇIKCEZA İNFAZ KURUMU  
-NİĞDE AÇIK CEZA İNFAZ KURUMU



”

DESIGN YOUR OWN  
SLAUGHTERHOUSE PLAN  
LET'S MAKE IT BUILD  
**REALITY TOGETHER.**

NOTES :



Meat  
Technologies  
*Et Teknolojileri*

TEKNOTES TASARIM MAKİNE SANAYİ VE TİCARET LİMİTED ŞİRKETİ  
TEKNOTES GROUP İNŞAAT İTHALAT İHRACAT VE ANONİM ŞİRKETİ

TÜRKİYE / TURKEY  
İMALATÇI - MANUFACTURER  
[www.mezbaha.com](http://www.mezbaha.com)  
[www.teknotesgroup.com](http://www.teknotesgroup.com)  
[www.slaughterhouseturkiye.com](http://www.slaughterhouseturkiye.com)

# HIGHLIGHT

## TEKNOTES TASARIM

supplies the most modern slaughter and integrated meat processing facilities with paddock, slaughter, meat processing, storage, refrigerator rooms and carriage systems for cattle, camel and sheep. We give importance to hygiene, ergonomics, safety, quality, animal health and butcher health at our company.



+90 555 893 98 01

+90 546 844 09 04



bilgi@mezbaha.com

[www.mezbaha.com](http://www.mezbaha.com)

[www.teknotesgroup.com](http://www.teknotesgroup.com)

[www.slaughterhouseturkiye.com](http://www.slaughterhouseturkiye.com)